

A3 is due after the break, but start on it NOW

1

Read HyperText entry on Study/work habits

When given new tasks to get done,
Procrastinate right from day one.
You think that's not fine?
It gives you more time
To catch up at last as you're done.

Assignment A3: Linked Lists

2

Idea: maintain a list (2, 5, 7) like this:

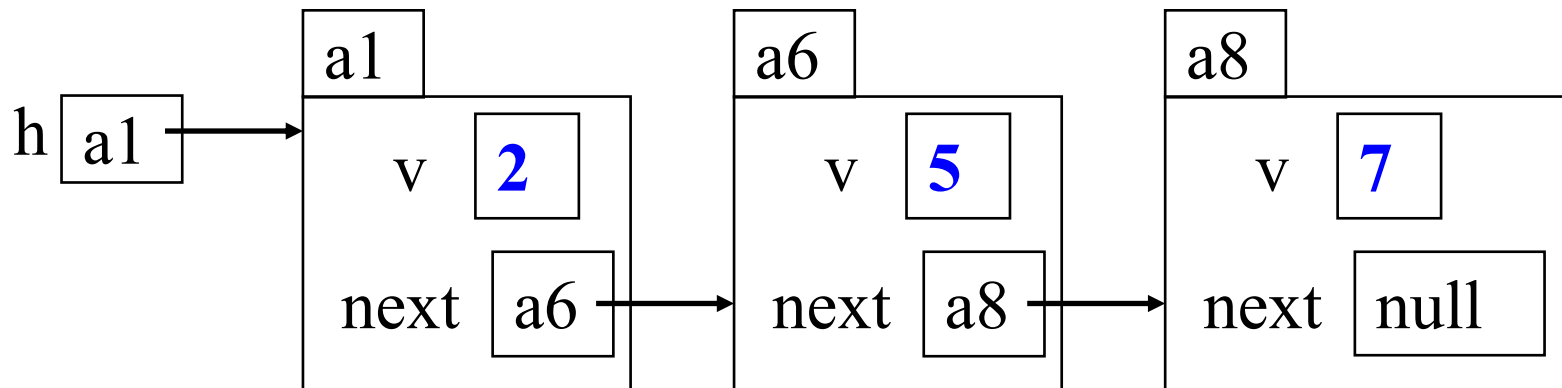

This is a singly linked list

To save space, we write names like a6 instead of N@35abcd00

How to insert a node at the beginning

3

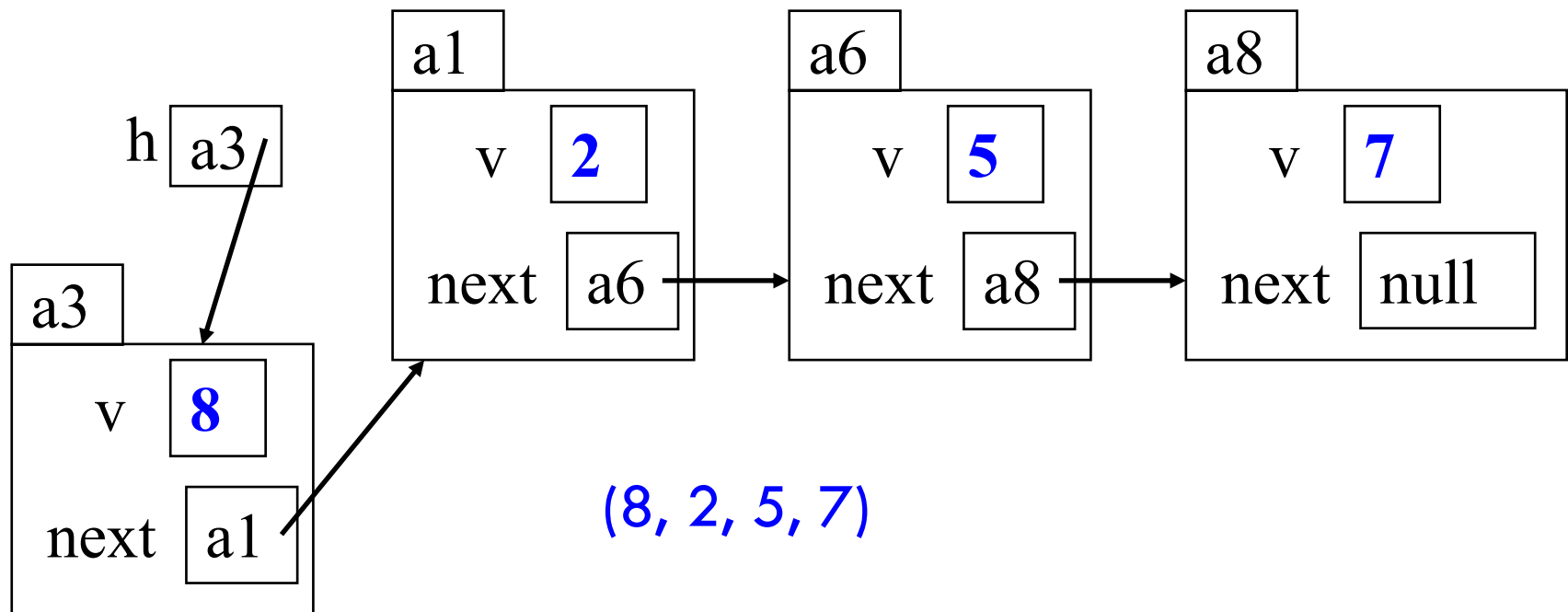
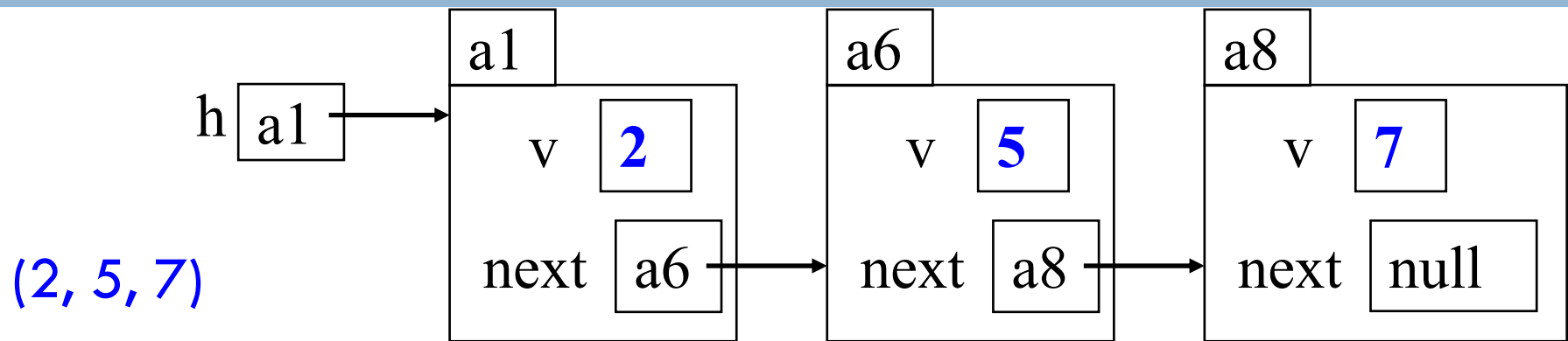

How to remove successor of a node in the middle

4

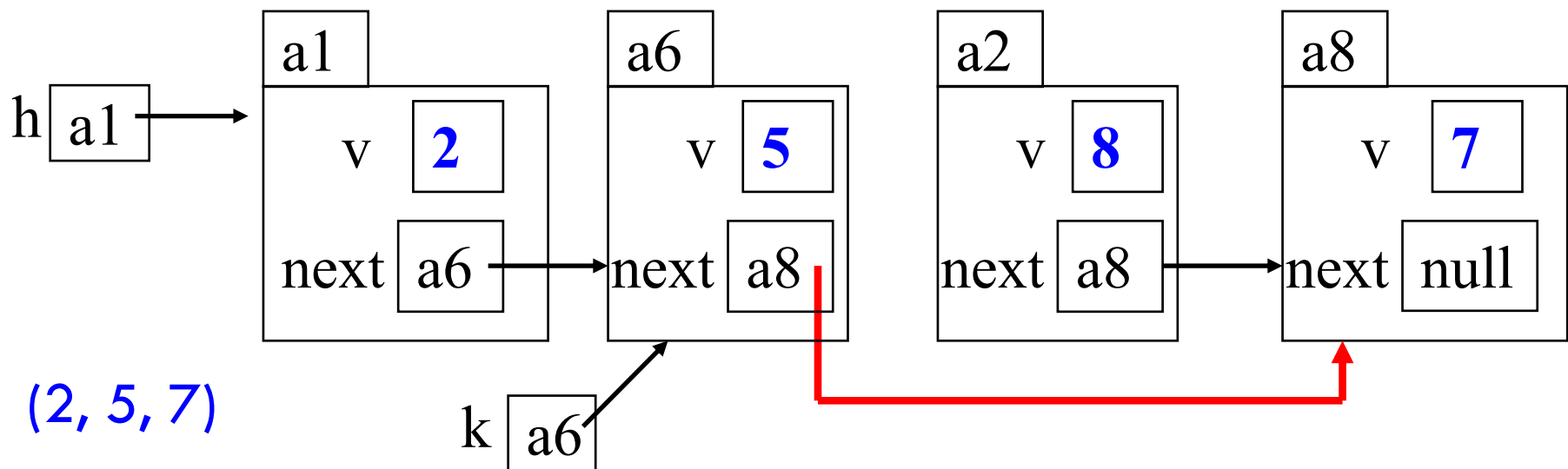
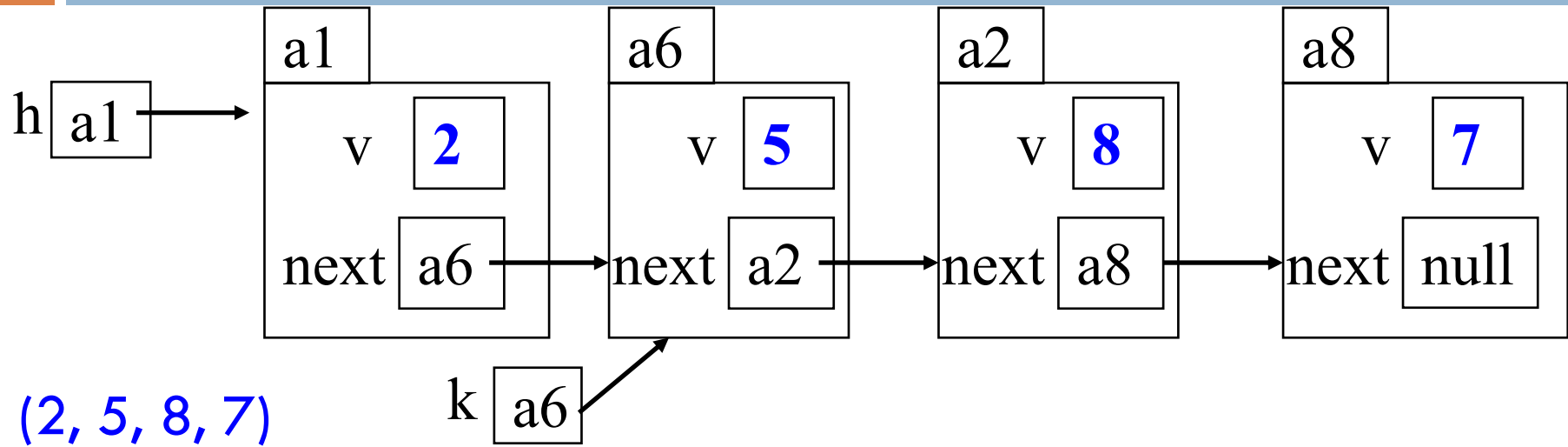

Assignment A3: Generics

5

```
public class LinkedList {  
    void add(Object elem) {...}  
    Object get(int index) {...}  
}
```

Values of linked list are
of class Object

```
public class LinkedList<E> {  
    void add(E elem) {...}  
    E get(int index) {...}  
}
```

You can specify what
type of values

```
ns = new LinkedList<Integer>();  
ns.add("Hello"); // error  
ns.add(5);  
String s = ns.get(0); // error  
int n = ns.get(0);
```

```
ss = new LinkedList<String>();  
ss.add("Hello");  
ss.add(5); // error  
String s = ss.get(0);  
int n = ss.get(0); // error
```

Assignment A3: Inner class

6

```
public class DList<E> {  
  field   private Node first;  
  ...  
  method public E first() { return first.val;  
  }  
  ...  
  class  private class Node {  
    private Node prev;  
    private E val;  
  }  
}
```

Outer class can **and should** use fields of class Node, even though they are private.